

1. Features

- Optimized for 800–960 MHz operation
- 4.0V nominal operating voltage
- Output power greater than 30dBm
- High PAE at maximum output power
- High/Low power mode control
- Low leakage current
- Single-ended 50 Ω input and output ports
- Fully on-chip matching circuitry

2. Applications

- Wi-SUN
- LoRa
- RFID
- Industrial IOT
- Connected Homes
- Automatic meter readers

3. Product Highlights

- Small package size
- Support low voltage vbat
- High Efficiency

4. Description

The Geo-Chip GC0609 is a high-performance, high-power PA (Power Amplifier), which is mainly designed for 800-960MHz ISM band applications such as Wi-SUN, LoRa, automatic meter readers and RFID.

Packaged in a compact LGA 2.5mm x 2mm x 0.75mm, the GC0609 is a 10-pad PA, exhibits high efficiency, low temperature variation, strong reliability and robust ruggedness.

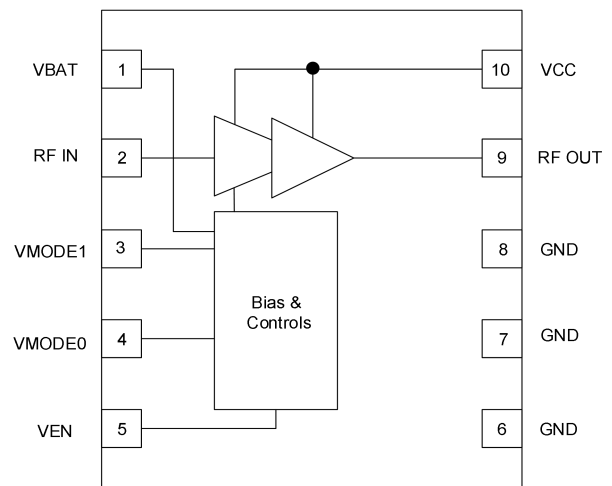

Figure 1 Block Diagram

CONTENTS

1. Features	1
2. Applications	1
3. Product Highlights	1
4. Description	1
5. Absolute Maximum Ratings	3
6. Pin Description	3
7. Recommended Operating Condition	4
8. Control Logic	4
9. Electrical Specifications	5
10. Typical Performance Curves	6
11. Application Schematic	7
12. Package Dimensions	7
13. Part Marking	8
14. Packaging Information	8
15. Disclaimer	9
16. Ordering Information	9
17. Revision Record	9

5. Absolute Maximum Ratings

Parameter	Range	Unit	Condition
RF Input Power	5	dBm	
Supply Voltage	4.5	Volts	
Supply Voltage	5	Volts	
Enable Control Voltage	3.6	Volts	
Mode Control Voltage	3.6	Volts	
Operating Temperature	-40~125	°C	
Storage Temperature	-55~150	°C	
ESD (HBM)	+2000	Volts	
ESD (CDM)	+750	Volts	

Table 1

6. Pin Description

Name	Pin	Description
RF IN	2	RF signal input
RF OUT	9	RF signal output
VBAT	1	Power supply for digital and internal drive PA
VCC	10	Power supply for last stage PA
VMODE	3,4	Digital Control signal input for mode selection
VEN	5	PA Enable Control signal
GND	6,7,8	Ground

Table 2

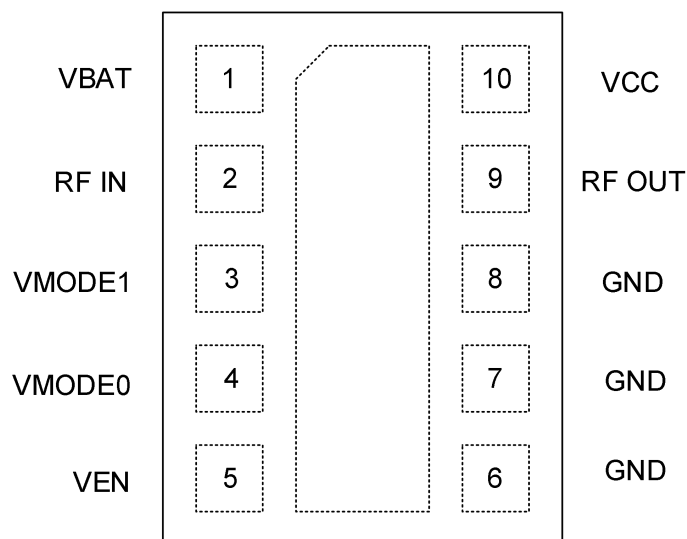

Figure 2 GC0609 Pinout (Top view)

7. Recommended Operating Condition

Parameter	Specification			Unit	Condition
	Min	Typ	Max		
Operating Frequency	800	----	960	MHz	800
Supply Voltage	2.1	3.3	3.6	Volts	2.1
Supply Voltage	0.3	4	4.2	Volts	0.3
Enable Control Voltage High	1.2	----	3.3	Volts	1.2
Enable Control Voltage Low	0	----	0.3	Volts	0
Mode Control Voltage High	1.2	----	3.3	Volts	1.2
Mode Control Voltage Low	0	----	0.3	Volts	0
Operating Temperature	-40	+25	+105	°C	-40

Table 3

8. Control Logic

Mode	VEN	VMODE0	VMODE1	VBAT & VCC
High Bias Mode	1	0	0	ON
Low Bias Mode	1	1	1	ON
Low Bias Mode_Temp	1	1	0	ON
Power down mode	0	X	X	ON

Note: "1" denotes high voltage state (> 1.2 V)
 "0" denotes low voltage stage (< 0.3 V) at control pins
 "X" denotes do not care: either "1" or "0" can be applied
 "Low Bias Mode_Temp" The quiescent current and small signal gain is less sensitive to temperature.

Table 4

9. Electrical Specifications

VBAT=3.3V, VCC=4V, Temp=25°C, CW Test

Parameters	Min	Typ	Max	Units	Conditions
Frequency range	800	880	960	MHz	
High bias mode Gain		30.5		dB	Small signal Gain @ 880MHz
Low bias mode Gain		29		dB	
Low Bias Mode_Temp Gain		29.5			
Gain variation over frequency		1.5	2	dB	Small signal
Input return loss		-12		dB	Small signal
Output return loss		-6		dB	Small signal
Quiescent current		68		mA	High bias mode
		55		mA	Low bias mode
		58		mA	Low Bias Mode_Temp
Current consumption @30dBm,880MHz		550		mA	High bias mode
		535		mA	Low bias mode
		540		mA	Low Bias Mode_Temp
Saturated power	31	31.5		dBm	High bias mode
	31	31.5		dBm	Low bias mode
	31	31.5		dBm	Low Bias Mode_Temp
Power added efficiency @Psat, 880MHz		53		%	High bias mode
		55		%	Low bias mode
		55		%	Low Bias Mode_Temp
Second harmonic			-10	dBm	High bias mode @ 30dBm
			-10		Low bias mode @ 30dBm
			-10		Low bias Temp @ 30dBm
Third harmonic			-15	dBm	High bias mode @ 30dBm
			-15		Low bias mode @ 30dBm
			-15		Low bias Temp @ 30dBm
Power down mode current			1	uA	
DC Enable time*1			3	us	
Mode switching time*2			3	us	
Ruggedness	No damage or permanent performance degradation				Output VSWR = 8:1All phase angles, RF IN = 3 dBm
Stability					Output VSWR = 6:1All phase angles

Table 5

10. Typical Performance Curves

10.1 S Parameters @ Low Bias Temp Mode

Conditions: VCC=4.0V, VBAT=VEN=VMODE0=3.3V, VMODE1=0V, Temp=25°C

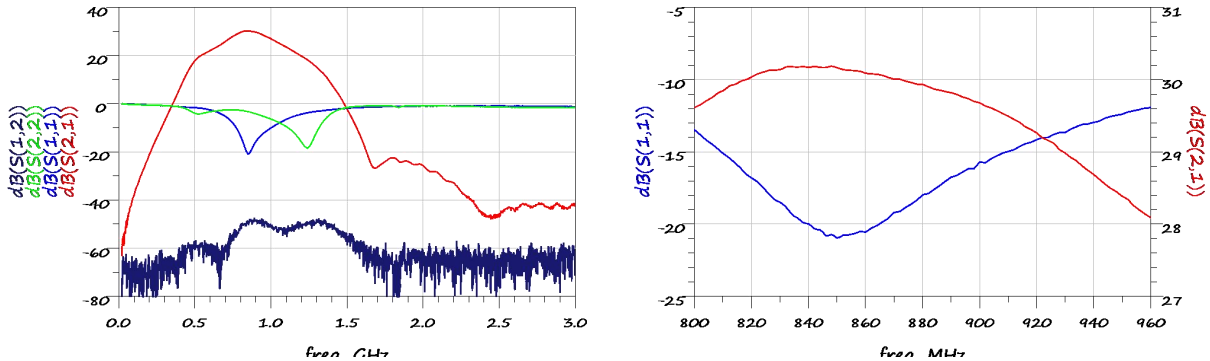

Figure 3

10.2 Efficiency & Current @ Low Bias Temp Mode

Conditions: VCC=4.0V, VBAT=VEN=VMODE0=3.3V, VMODE1=0V, Temp=25°C

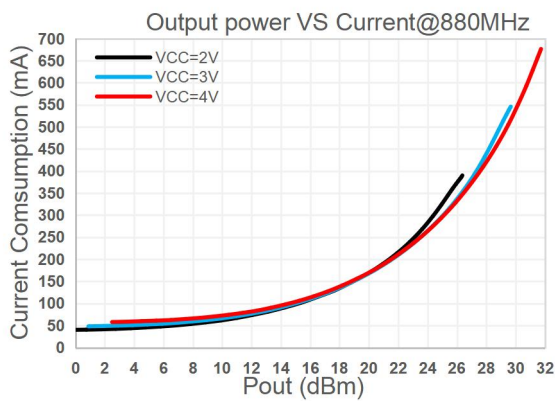

Figure 4

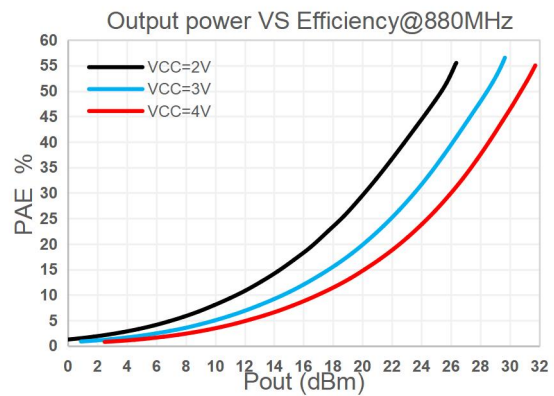

Figure 5

10.3 Gain vs Pout

Conditions: VBAT=VEN =3.3V, Temp=25°C

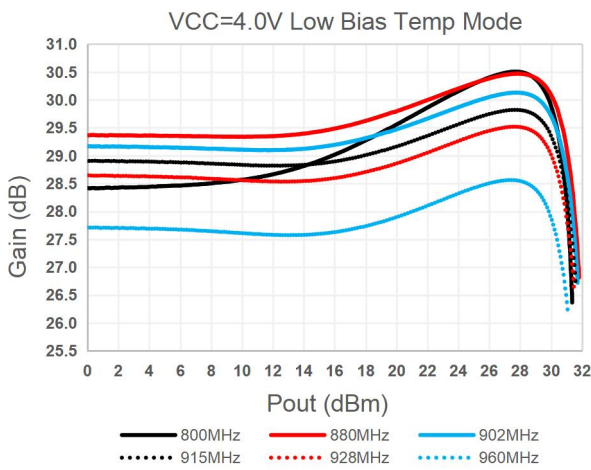

Figure 6

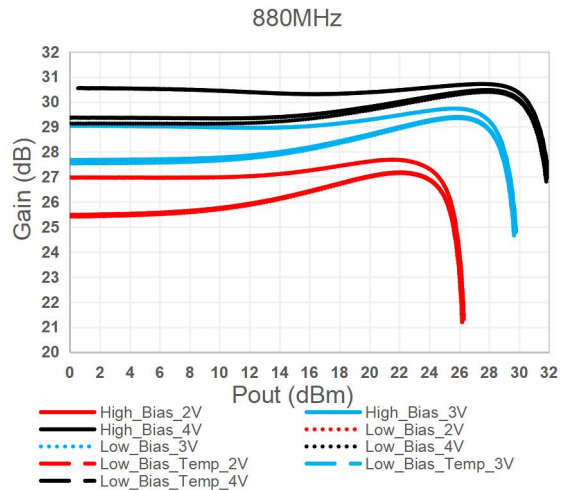

Figure 7

11. Application Schematic

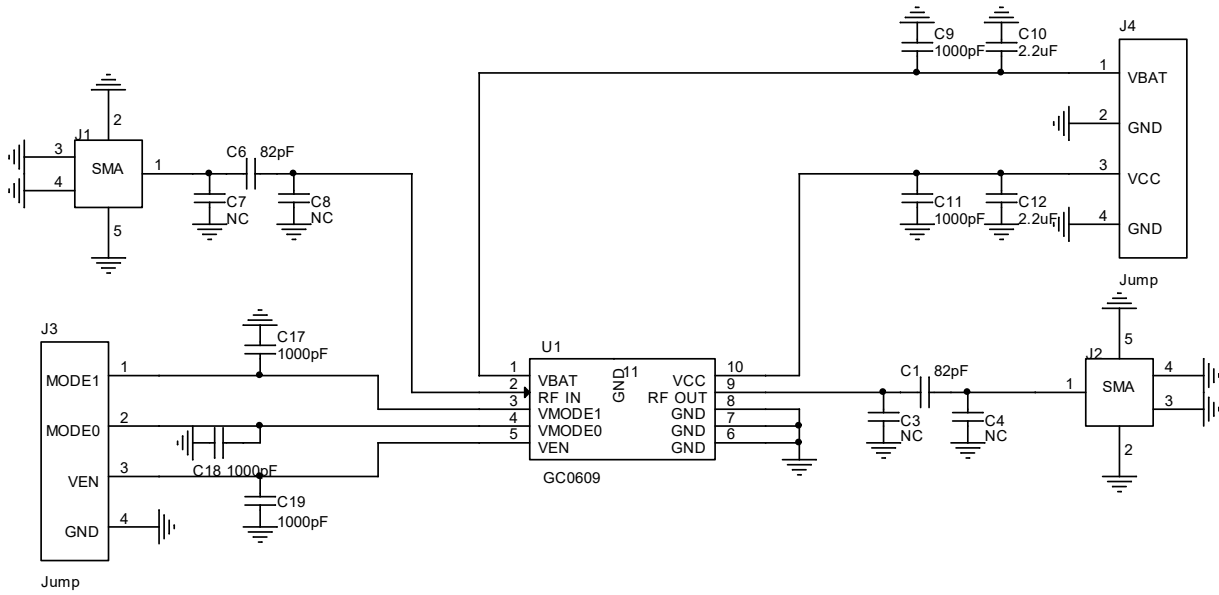

Figure 8

12. Package Dimensions

Symbol	Dimension in mm		
	Min	Typ	Max
A	0.67	0.75	0.81
A1	0.00	---	0.03
A2	---	---	0.78
D	1.90	2.00	2.10
E	2.40	2.50	2.60
D1	---	1.55	---
E1	---	2.031	---
e1	---	0.505	---
e2	---	0.5105	---
a1	0.20	0.25	0.30
b1	0.205	0.255	0.305
a2	0.20	0.25	0.30
b2	0.2175	0.2675	0.3175
f1	---	0.50	---
f2	---	0.70	---
f3	---	2.10	---
f4	---	2.30	---

Table 6

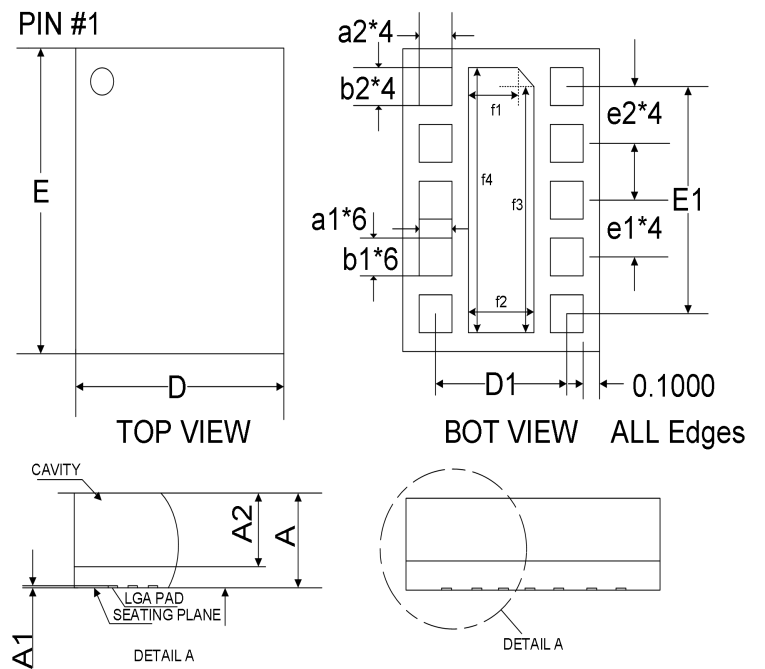

Figure 9

13. Part Marking

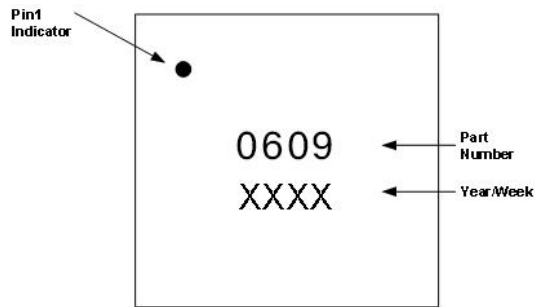

Figure 10 Typical Part Markings (Top View)

14. Packaging Information

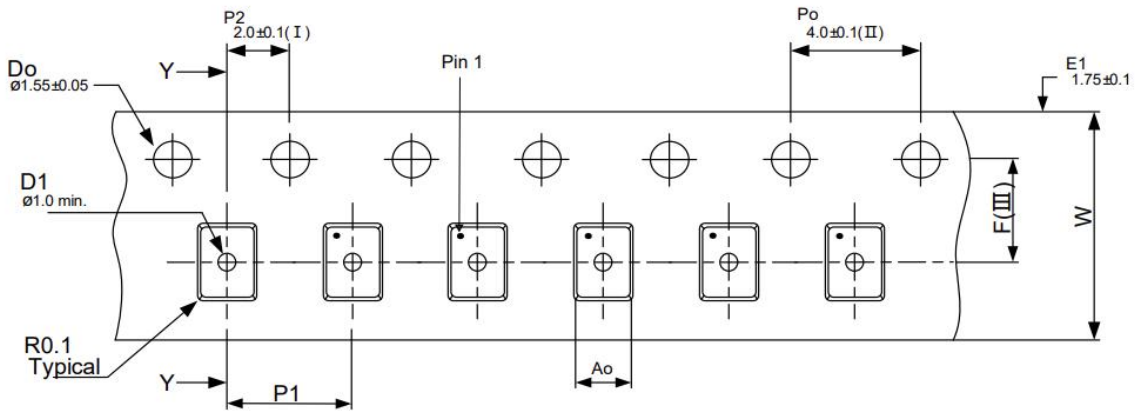

Figure 11 Packaging Information

Ao	2.25 +/-0.05
Bo	2.80 +/-0.05
Ko	1.10 +/-0.1
F	3.50 +/-0.05
P1	4.00 +/-0.1
W	8.00 +0.3/-0.1

- (I) Measured from centreline of sprocket hole to centreline of pocket.
- (II) Cumulative tolerance of 10 sprocket holes is ± 0.20 .
- (III) Measured from centreline of sprocket hole to centreline of pocket.
- (IV) Other material available.

ALL DIMENSIONS IN MILLIMETRES UNLESS OTHERWISE STATED.

Package Type	Unit Size	Max Reel Diameter	Type Width	Pocket Pitch	Reel Capacity
Tape and Reel	2.5mm x 2mm x 0.75mm	13"	8mm	4mm	3000

15. Disclaimer

Information in this document is provided in connection with Hangzhou Geo-chip Technology Co., Ltd. These materials are provided by Geo-chip as a service to its customers and may be used for informational purposes only. The information provided here is believed to be reliable; Geo-chip assumes no responsibility for errors or omissions in these materials. Geo-chip assumes no reliability for the use of this information and all such information should entirely be at the user's own risk. Specifications described and contained here are subjected to change without notice on the purpose of improving the design and performance.

All of this information described herein should not be implied or granted for any third party. Geo-chip does not authorize or warrant any Geo-chip products for use in the life support devices or systems.

For technical questions and additional information about Hangzhou Geo-chip Technology Co., Ltd.

Website: www.geochipinc.com

China Tel: + 86-571 26283530

16. Ordering Information

Model	Package	Packaging Form	Minimum Order Quantity

17. Revision Record

Version	Date	Description
1.91	2022/3	V1.91
1.92	2022/10	Updated Figure 10 and Figure 11